



COINDA CERAMICS

Quality and Service to the foundry industry



POURING BELLS

- ✓ The **high alumina formulation** offers **improved strength** and **resistance to thermal impact** and **abrasion** by molten steel
- ✓ Taper geometry **minimises aspiration** effects promoting **smooth metal flow**
- ✓ Designed and manufactured to form an **integrated system** with other Coinda products
- ✓ **Lighter and stronger** for ease in assembly
- ✓ **Accurate and consistent dimensions**

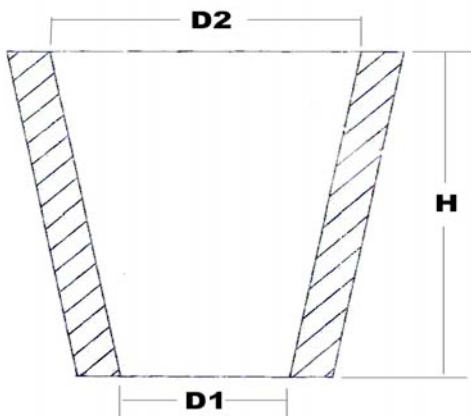

D1 (mm)	D2 (mm)	H (mm)	QTY PER CARTON
65	170	230	140
73	180	230	120
80	185	295	120
100	180	230	100
120	220	230	100

NEED SOMETHING DIFFERENT ?

Direct access to our design and manufacturing facilities offers the flexibility to respond quickly to your specific needs. So, if you need something different

TALK TO US

Orders can be placed directly
with Coinda on

FAX : (03) 9729 4811

Coinda Ceramics That's Casting with